

CNC Double Column Machining Center

Small size Model with UDM Series ด้วยระยะเลื่อนแกน X ที่ 2200 มม. ถึง 3200 มม.
ระยะเลื่อนแกน Y ที่ 1200 มม. ถึง 1500 มม.

UDM-2212, 2215, 3212, 3215 ขนาด ยอดนิยม สำหรับงาน Mould & Die.

ตัวแทนจำหน่ายประเทศไทย : บริษัท สยาม เอลมาเทค จำกัด



MACHINE SPECIFICATIONS		UDM 3000 Series			
		UDM-2212	UDM-2215	UDM-3212	UDM-3215
TABLE	Table Size	2000 x 1100	2000 x 1300	3000 x 1100	3000 x 1300
	T-slots Size	22			
	Maximum Load	5000	4000	4500	5000
TRAVEL	X-Axis	2200	2200	3200	3200
	Y-Axis	1200	1500	1200	1500
	Z-Axis	750			
SPINDLE	Spindle Servo Motor - cont./30min.	11/15 (22/26)			
	Speed	4000			
	Taper	7/24 Taper, ISO 50, BT-50			
DISTANCES	Between Two Columns	1300	1500	1300	1500
	Spindle Nose to Table Surface	200 - 950			
FEED RATE	Rapid Feed Rate X/Y/Z	20 / 20 / 15			
	Minimum Feeding	0.001			
	Cutting Feed Rate	8			
	Max. of Tools	0 (24 / 32 / 40)			
ATC	Tool Change Time - Tool T (approx.)	8 (Arm Type)			
	Max. Tool Diameter / Length	Ø125/Ø200 (Without Adjunct Tool) / Length 350			
	Max. Tool Weight	15			
	Coolant Tank Volume	240			
COOLANT & LUBRICATION	Hydraulic Tank Volume	70			
	Lubrication Tank Volume	8			
	Power Required	40			
METEORIOUS	Pressurized Air	5 - 8			
	Hydraulics Required	70			
	Machine Weight (approx.)	17000	17500	21000	21500
	Controller	FANUC 0i MF / FANUC 32-B / 31-BI / MITSUBISHI, SIEMENS, HEIDENHAIN			

* Specifications are subject to change without prior notice.

STANDARD ACCESSORIES :	11. MPIS	OPTIONAL ACCESSORIES :	1. 6000RPM direct drive spindle (DRP)	10. FANUC 32-B (31-BI) Controller
1. Glass window type splash guard	12. Machine inspection lights	2. 1 Y and Z axes with linear scales	2. 1 Y and Z axes with linear scales	11. MITSUBISHI Controller
2. Programmable coolant system	13. Operation manuals	3. Axis tool length & diameter measurement (TS-278)	3. Axis tool length & diameter measurement (TS-278)	12. SIEMENS Controller
3. Automatic lubrication system	14. Controller manuals and circuit diagram	4. CNC rotary table	4. CNC rotary table	13. HEIDENHAIN Controller
4. Spindle air bleed system	15. Auto power off	5. JTC 24, 32, 40 tools	5. JTC 24, 32, 40 tools	14. 12000RPM or 15000RPM direct drive spindle (DRP) (2 only for FANUC or MITSUBISHI controller)
5. Working Lamp	16. RS-232C terminal interface	6. Coolant through spindle	6. Coolant through spindle	
6. Alarm lamp for abnormal situations	17. Spindle coolant system	7. Oil-lead holder	7. Oil-lead holder	
7. Indication lamp for dwell & end of job	18. Hydraulic system	8. Oil mist device	8. Oil mist device	
8. Leveling tools & pads	19. Heat exchanger	9. Air conditioner for electrical cabinet	9. Air conditioner for electrical cabinet	
9. Chip paper & chain type chip conveyors	20. FANUC 0i MF Controller			
10. Toolbox with spanners & wrenches				

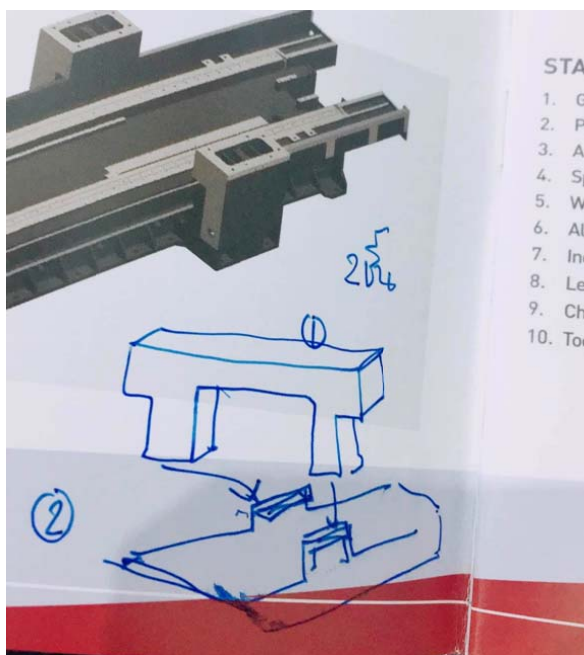

Siam Elmatech Co.,Ltd.

ID LINE : [siamelmatech-md](https://www.siamelmatech.com)

E-MAIL : ukofset@ksc.th.com

MOBILE : 089-776-2912